



Leyard LN Series

Indoor & Outdoor Rental LED Display

Leyard® LN Series is a versatile, efficient and flexible rental LED display solution. Its user-friendly modular design and lightweight structure make it quick and easy to assemble and dismantle for exhibitions, concerts, conferences, sporting events and more. The LED cabinets can be adjusted at -10° to 10° angles to form convex or concave LED video walls that can be hung or stacked, making it a great option for any temporary indoor event or occasion. Curved and double-tall models are available for increased application versatility.



Edge Protection Design
Preventing collisions or damage during installation or transportation



Lightweight and Portable
Ease of handling and quick setup, adaptable for various events



Positioning Arc Lock
Curvable -10° to 10° adjustable design



Easy Maintenance
Cabinet 100% rear maintenance



Outdoor Waterproof
Durable for outdoor use, maintains clear visibility



2-Year Warranty
Leyard LED Standard Limited Warranty

- 1.9, 2.6, 2.9, 3.9 & 4.8mm pixel pitches
- Lightweight & portable design
- Curvable -10° to 10° adjustable design
- Waterproof for outdoor use



LN-R 45° Cut-corner



LN-C S-shaped Design



LN-C General Cabinet



Disponibile en:
SHOWCO.com.mx
marketing@showco.com.mx
☎ (56) 6227 7437

LACARA
#OCULTA DEL
ESPECTÁCULO
f @ @showco.mx

Flexibility and Convenience

Calming Appearance, Easy to Use

Leyard LN Series rental LED displays have a modular and lightweight structure, making them easy to install and dismantle. They also have a user-friendly design, easy maintenance and quick setup. This convenient structure allows for easy transport and setup for various events and occasions.

The **Quick Lock** for Leyard LN Series cabinets is designed to provide a convenient and efficient way to assemble and disassemble the cabinets. It allows users to quickly and securely lock the cabinets together without the need for any tools or special skills.

The **Angle Adjustment Lock** allows the cabinets to be adjusted to different angles, creating a curved display surface that can be customized to fit the specific requirements of the event.

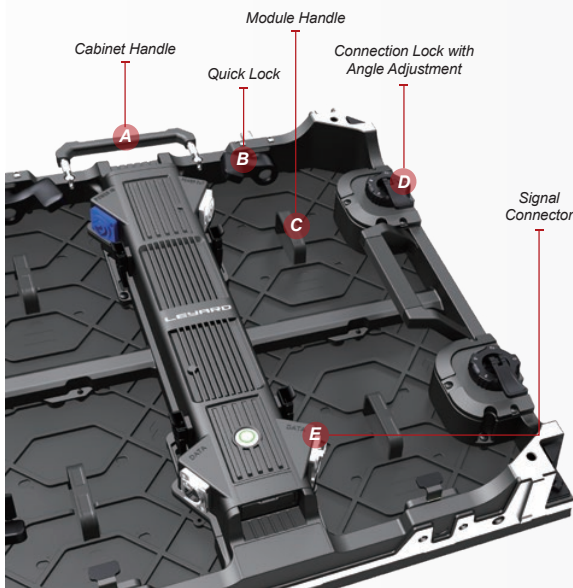

Lightweight and Portable

The displays are lightweight and designed for portability, making them easy to transport and set up.

Seamless Design

The displays are designed to be seamlessly connected, creating a larger and more immersive video wall.

Wide Viewing Angle

The displays have a wide viewing angle, so content can be seen clearly from different angles and distances.

Display Versatility

The displays support multiple splicing such as straight, arc, right angled, and curved. This flexibility allows for unique and creative installations, perfectly tailored to enhance any space.



High Quality Die-casting aluminum

High-quality die-cast aluminum cabinets for LED displays are durable, lightweight, and easy to install. They also offer excellent heat dissipation and protection against moisture and dust, ensuring the longevity and performance of the LED display.



Special Protective Design

> Special protective design can prevent LED damage caused by unexpected impact.

> Multi-function locks which support self-locking, connection, and precise gap minimization make seamless splicing easy.

Edge Protection Design

Corner protectors around the LED enclosure defend against collisions or damage during installation or transportation, extending the lifespan of the LED video wall.



Disponible en:
SHOWCO.com.mx
marketing@showco.com.mx
☎ (56) 6227 7437

LACARA
#OCULTA DEL
ESPECTÁCULO
f @ showco.mx

Cabinet 100% Rear Maintenance

For rental LED display cabinets, it is important to have LED display modules and power supplies that can be easily disassembled and assembled to ensure efficient setup and teardown.

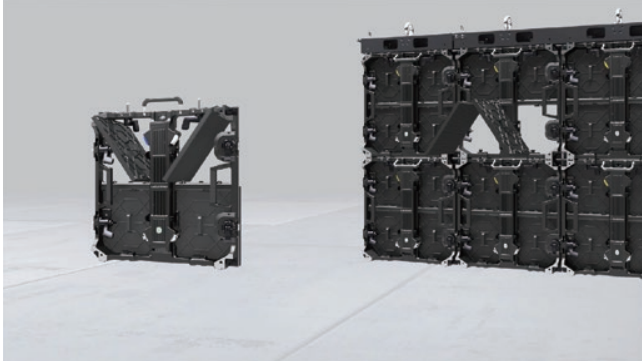

LED Modules Support Front Maintenance

Using a specially-designed maintenance tool, an installer can quickly replace the module from the front, greatly saving labor and time costs. (Limited to indoor version only)



Supports Installation with a Combination of Two Different Cabinet Sizes

The Leyard LN Series offers two different cabinet heights (500mm, 1000mm) to choose from, which can be freely mixed and matched using connecting plates for flexible and quick installation.



Curvable Design, -10° to 10° Can be Adjusted

The curved angle adjustment feature allows the LED cabinets to be adjusted to different angles, creating a curved LED display surface that can be customized to fit the specific requirements of the event.

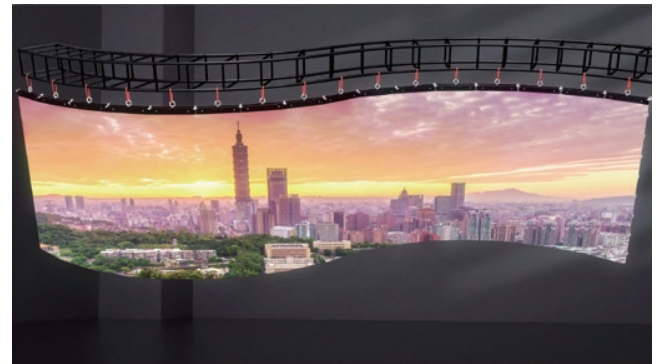

Hanging Mounting

A hanging beam can be used to provide a stable support structure. It can be adjusted to fit the size and weight of the LED display.

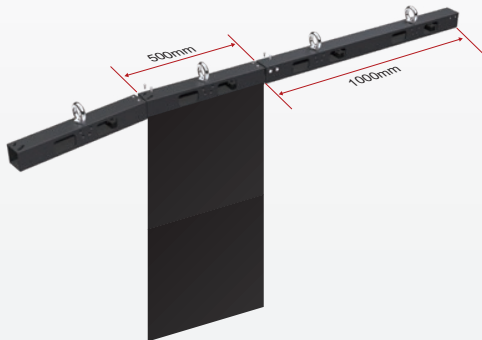

Standing Mounting

The LED display cabinet can be mounted on a stable base structure, which can be adjusted to the desired height and angle.

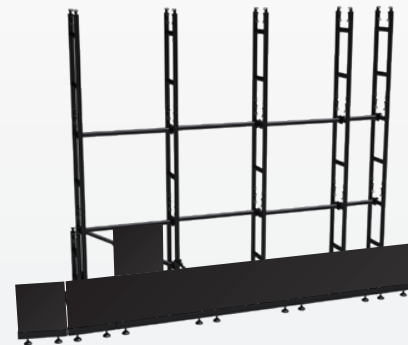

Disponible en:
SHOWCO.com.mx
marketing@showco.com.mx
☎ (56) 6227 7437

LACARA
#OCULTA DEL
ESPECTÁCULO
f @ showco.mx

LN-R

45-degree Beveled Cabinet Designed Specifically for Creative Displays

The Leyard LN-R Series rental LED display cabinet allows the screen body to be easily combined into right angles, cubes, and other polygonal structures, providing more creative space for stages and exhibitions. This design increases the splicing flexibility of the video wall, making the layout more diverse and adaptable to the decorative needs of different venues. It also brings a more unique and stunning visual experience to the audience, especially suitable for high-end events and brand displays, enhancing the event's grade and viewing value.



LN-C

Efficient S-shaped Design A Single Cabinet can Achieve a Perfect S-shape

The Leyard LN-C Series curve LED display cabinet's S-shaped design has a unique curved display capability, which can realize creative video walls such as wave and cylindrical shapes, adding dynamism and a three-dimensional effect to the display. This design enhances visual impact and artistic beauty and captures the attention of the audience, increasing the appeal of advertisements or displayed content. The modular design of the S-shaped cabinet also facilitates quick installation and disassembly, adapting to various temporary display and event needs.

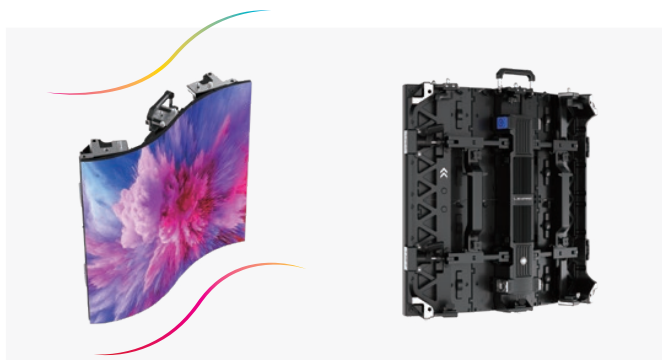

Disponible en:
SHOWCO.com.mx
marketing@showco.com.mx
☎ (56) 6227 7437

LACARA
#OCULTA DEL
ESPECTÁCULO
f @ showco.mx

Especificaciones

	LN2.6
Module Dimension (WxH, mm)	250x250 mm
Resolución cabinet (AnxAl)	192x192
	LN2.6
Tamaño cabinet (AnxAlxPr)	500x500x79 mm
Brillo, máx. (cd/m²)	1000 nits
Consumo de energía, máx. (W/m²)	600 W/m ²
Consumo de energía, típ. (W/m²)	200 W/m ²
Pixel Pitch (mm)	2.604 mm
Composición módulo (AnxAl)	2x2
IP Level	IP50
Alimentación	AC100 to 240V (50/60Hz)
Frame Rate (Hz)	50&60 Hz
Contraste	5000:1
Cabinet Weight (kg)	7.5 kg
Temperatura de color (K)	3000 to 10000K Adjustable
Ángulo de visión, horizontal (°)	160°
Ángulo de visión, vertical (°)	140°
Refresh Rate (Hz)	7680 Hz



Disponible en:
SHOWCO.com.mx
marketing@showco.com.mx
☎ (56) 6227 7437

LACARA
#OCULTA DEL
ESPECTÁCULO
f @ showco.mx